

Tools for Intel® x86/x64



Release 09.2024

MANUAL

TRACE32 Online Help

TRACE32 Directory

TRACE32 Index

TRACE32 Documents	
ICD In-Circuit Debugger	
Processor Architecture Manuals	
x86	
Tools for Intel® x86/x64	1
Introduction	3
Legend	3
TRACE32 QuadProbe	4
QuadProbe and PowerDebug Module USB 3.0	5
Delivery Content	5
Assembling	7
Extra (CONV-MIPI60Q-XDP60)	10
Extras (POWER Connector)	10
Extra (USB-2-CABLE)	11
Extra (TRIGGER-CONNECTOR)	11
QuadProbe and PowerDebug PRO	12
Delivery Content	12
Assembling	14
Extra (CONV-MIPI60Q-XDP60)	17
Extras (POWER Connector)	17
Extra (USB-2-CABLE)	18
Extra (TRIGGER-CONNECTOR)	18
Extra	19
Extra (USB-2-CABLE)	19
Extras (TRIGGER-CONNECTOR)	20

Introduction

This manual presents the delivery content for the individual Lauterbach tools for Intel® x86/x64 and describes how the individual components are assembled to a ready-to-use debug tool.

Legend

Most TRACE32 products have on their back a **sticker** that provide **identification information**. The order code and the subsequent product name printed there are used in the **delivery content** photos to identify the individual products.



Some products are additionally marked as **Variant**. Variant means, there is an alternative for the shown product, which is functionally identical.

Some products are additionally marked as **Extra**. Extra products are delivered as standard, however, are not required in the default configuration. When these products are needed and how they are integrated into the configuration, is described in an extra chapter.

TRACE32 QuadProbe

The TRACE32 QuadProbe is designed especially for Intel® x86/x64 server platforms. It provides debug capability for up to 4 debug connectors on a single target.

Debug licenses are programmed into the QuadProbe. The license to debug the Intel® x86/x64 architecture **DEBUG-INTEL-X86-A** is programmed in any case. Additional stickers on the back will indicate further licenses.



The QuadProbe needs a POWER DEBUG module to operate. This manual describes the following standard debugger configurations:

- QuadProbe and PowerDebug Module USB 3.0
- QuadProbe and PowerDebug PRO Ethernet

Delivery Content

In order to assemble a “QuadProbe and PowerDebug Module USB 3.0” debugger you need:

Package QP Intel x86/x64 Single MIPI60-Q

Deliveries of LA-4614 “Package QP Intel x86/x64 Single MIPI60-Q” or LA-4616 “Package QP Intel x86/x64 Single MIPI60-Q Long” comprise the following parts:

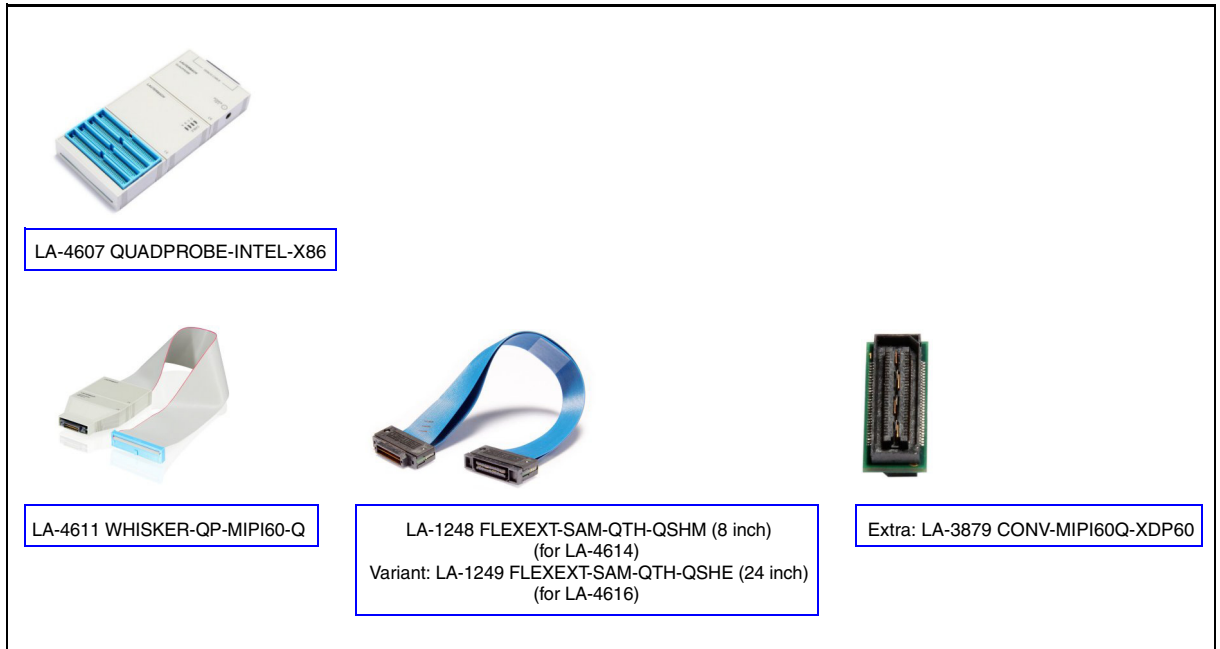

If you want to use more than a single WHISKER-QP-MIPI60-Q, you need further sets comprising of:

- LA-4611 — WHISKER-QP-MIPI60-Q
- LA-1248 or LA-1249 — flex extension cable
- LA-3879 (optional) — converter to XDP60 pin-out

A delivery of **LA-3500 PowerDebug Module USB 3.0** comprises the following parts:



1. Assemble the QUADPROBE.

Connect the flex extension cable to the WHISKER-QP-MIPI60-Q.



Connect the WHISKER-QP-MIPI60-Q to the QUADPROBE.

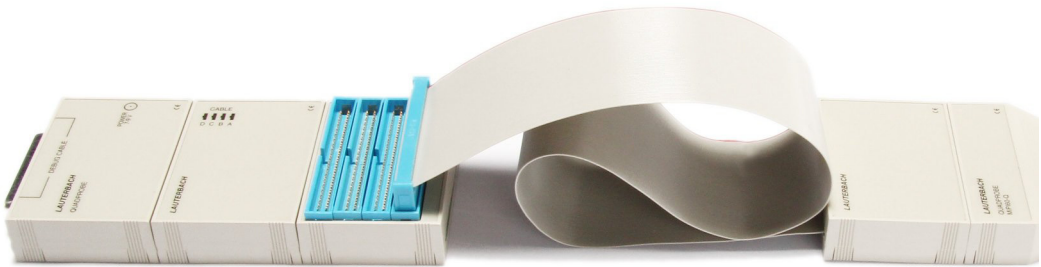

The QUADPROBE provides 4 sockets for the WHISKER-QP-MIPI60-Q cables. The outer socket is socket A. The first WHISKER-QP-MIPI60-Q has to be connected to this socket.

If you are using more than one WHISKER-QP-MIPI60-Q the assembling order is as follows:

The second WHISKER-QP-MIPI60-Q has to be connected to socket B.

The third WHISKER-QP-MIPI60-Q has to be connected to socket C.

The fourth WHISKER-QP-MIPI60-Q has to be connected to socket D.

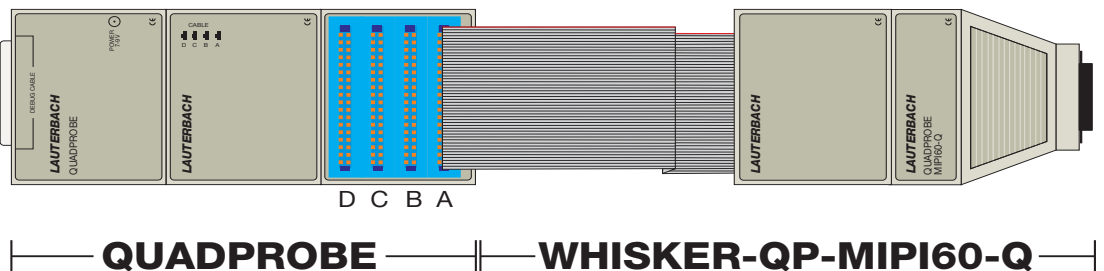

2. Connect the QUADPROBE to the POWER DEBUG INTERFACE / USB 3.

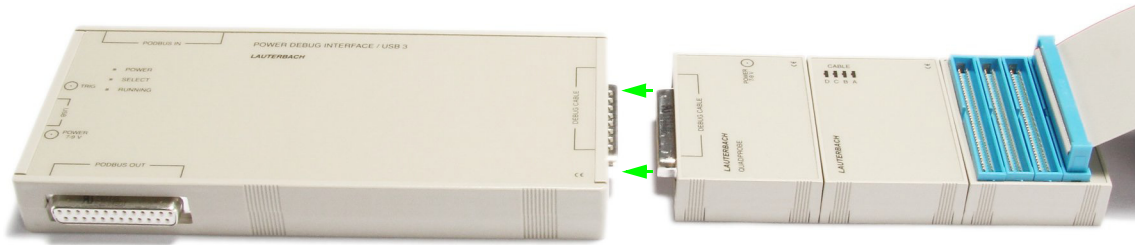

3. Connect the USB cable to POWER DEBUG INTERFACE / USB 3. Then connect the power supply to POWER DEBUG INTERFACE / USB 3 to power the tool.



4. Connect the tool, respectively the WHISKER-QP-MIPI60-Q to your target.

For the standard assembling it is presumed that your target provides one or more “Intel® MIPI60 Converged” connectors, you can connect the WHISKER-QP-MIPI60-Q cables via the flex extension cable directly.

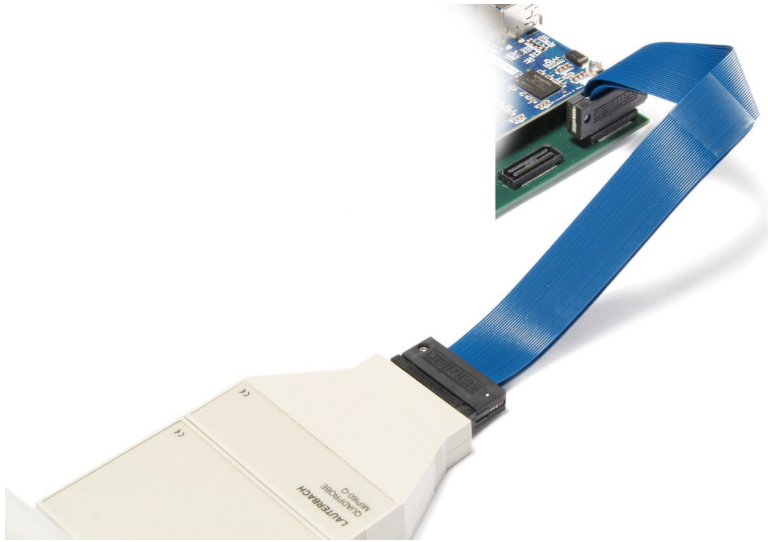

If your target provides one or more Intel® XDP60 connectors, please refer to [“Extra \(CONV-MIPI60Q-XDP60\)”](#), page 10.

If the “Intel® MIPI60 Converged” connectors are numbered in ascending order, it is recommended:

- to connect the WHISKER-QP-MIPI60-Q connected to the QUADPROBE socket A to the connector with the lowest number.
- to connect the WHISKER-QP-MIPI60-Q connected to the QUADPROBE socket B to the connector with the next higher number and so on.

5. Start the TRACE32 software.

6. Power your target.

Information on how to set up your debug environment can be found in the following manuals:

- [“Intel® Application Note for Server Setup”](#) (app_x86_server.pdf)
- [“Intel® x86/x64 Debugger”](#) (debugger_x86.pdf).

Extra (CONV-MIPI60Q-XDP60)

If your target provides one or more Intel® XDP60 connectors, you have to use the converter CONV-MIPI60Q-XDP60. It converts the “Intel® MIPI60 Converged” pinout from the WHISKER-QP-MIPI60-Q to Intel® XDP60 pinout.

Connect CONV-MIPI60Q-XDP60 to each flex extension cable for each WHISKER-QP-MIPI60-Q.

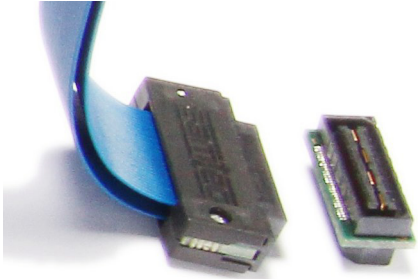

Then continue as described on the previous page.

Extras (POWER Connector)

POWER DEBUG INTERFACE / USB 3 is able to drive a QUADPROBE with 4 WHISKER-QP-MIPI60-Q cables.

Older POWER DEBUG modules do not have enough power. For these modules the QUADPROBE is equipped with an additional POWER connector.

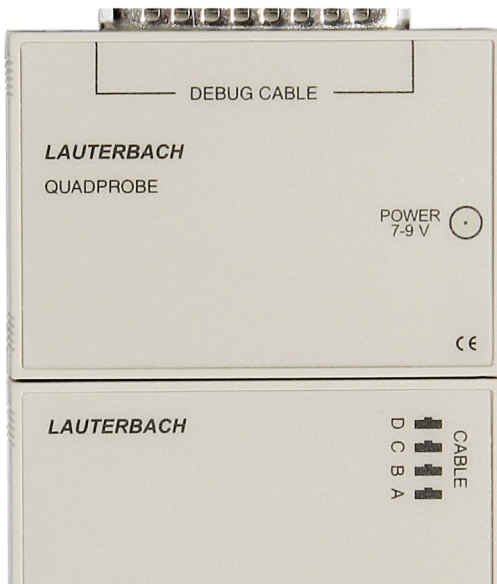

Both power supplies offered by Lauterbach are suitable:

- LA-1952 POWERSUPPLY-PP
- LA-1955 POWERSUPPLY-SPU65

Extra (USB-2-CABLE)

For more information refer to [“Extra \(USB-2-CABLE\)”](#), page 19.

Extra (TRIGGER-CONNECTOR)

For more information refer to [“Extras \(TRIGGER-CONNECTOR\)”](#), page 20.

Delivery Content

In order to assemble a “QuadProbe and PowerDebug PRO” debugger, you need:

Package QP Intel x86/x64 Single MIPI60-Q

Deliveries of LA-4614 “Package QP Intel x86/x64 Single MIPI60-Q” or LA-4616 “Package QP Intel x86/x64 Single MIPI60-Q Long” comprise the following parts:

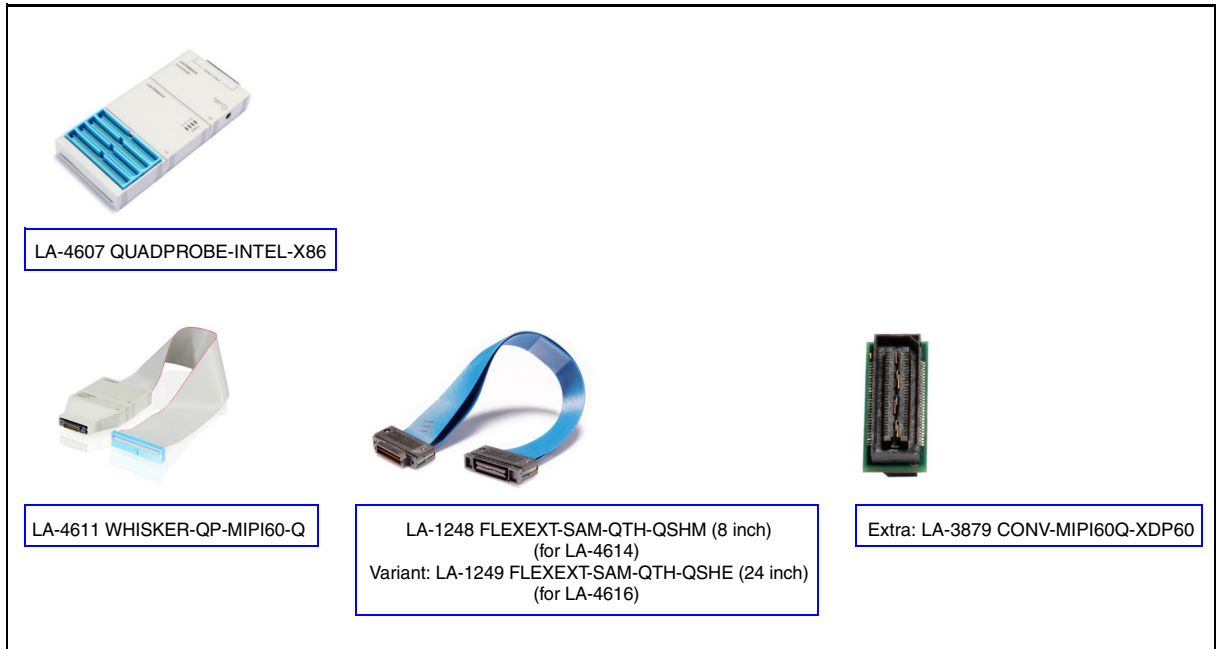

If you want to use more than a single WHISKER-QP-MIPI60-Q, you need further sets comprising of:

- LA-4611 — WHISKER-QP-MIPI60-Q
- LA-1248 or LA-1249 — flex extension cable
- LA-3879 (optional) — converter to XDP60 pin-out



LA-3505 POWER-DEBUG-PRO



LA-1955 POWERSUPPLY-SPU65



Extra: LA-7411 TRIGGER-CONNECTOR



LA-1943 USB-3-CABLE



Extra: LA-1942 USB-2-CABLE

1. Assemble the QUADPROBE.

Connect the flex extension cable to the WHISKER-QP-MIPI60-Q.



Connect the WHISKER-QP-MIPI60-Q to the QUADPROBE.

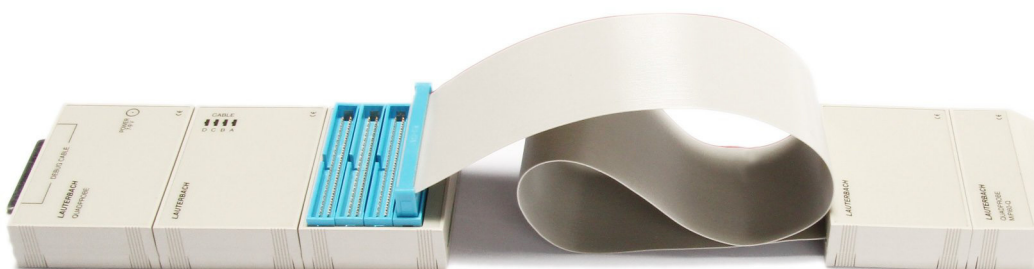

The QUADPROBE provides 4 sockets for the WHISKER-QP-MIPI60-Q cables. The outer socket is socket A. The first WHISKER-QP-MIPI60-Q has to be connected to this socket.

If you are using more than one WHISKER-QP-MIPI60-Q the assembling order is as follows:

The second WHISKER-QP-MIPI60-Q has to be connected to socket B.

The third WHISKER-QP-MIPI60-Q has to be connected to socket C.

The fourth WHISKER-QP-MIPI60-Q has to be connected to socket D.

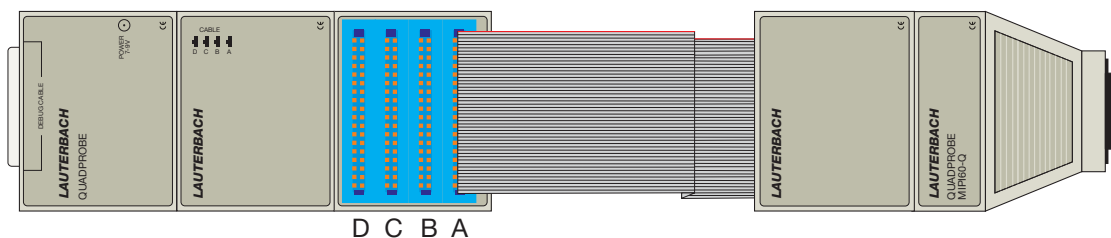

—| **QUADPROBE** |— || —| **WHISKER-QP-MIPI60-Q** |—

2. Connect the QUADPROBE to POWER-DEBUG-PRO.

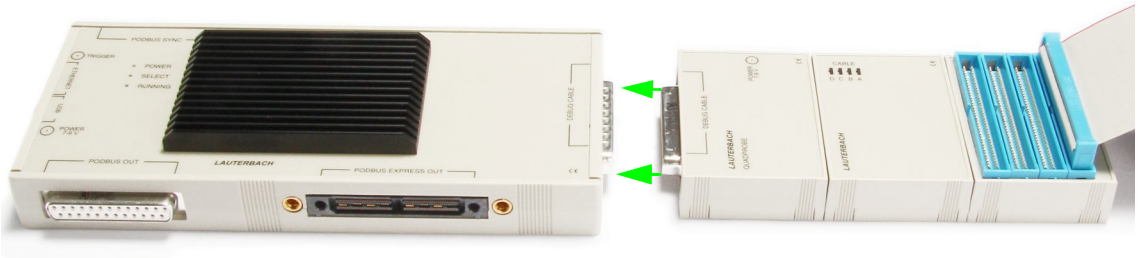

3. Connect the USB cable or a ethernet cable to POWER DEBUG PRO.

The Lauterbach standard delivery does not contain an ethernet cable.

Then connect the power supply to POWER DEBUG PRO to power the tool.



4. Connect the tool, respectively the WHISKER-QP-MIPI60-Q to your target.

For the standard assembling it is presumed that your target provides one or more “Intel® MIPI60 Converged” connectors, you can connect the WHISKER-QP-MIPI60-Q cables via the flex extension cable directly.

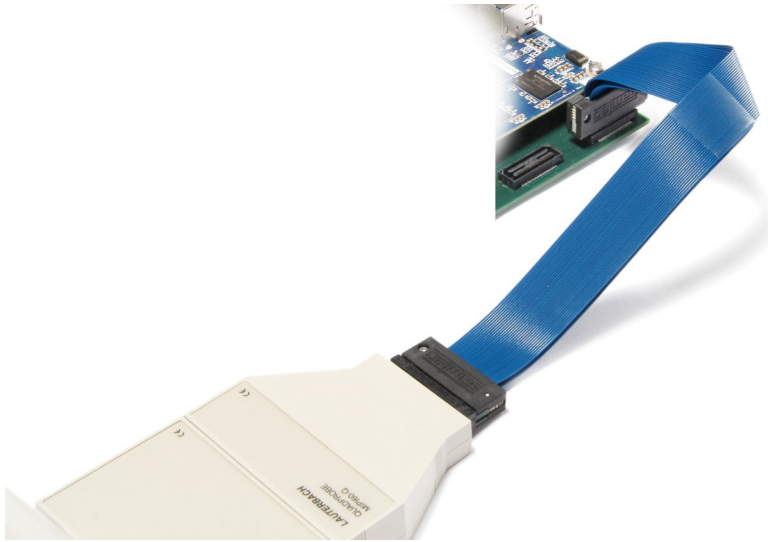

If your target provides one or more Intel® XDP60 connectors, please refer to [“Extra \(CONV-MIPI60Q-XDP60\)”](#), page 10.

If the “Intel® MIPI60 Converged” connectors are numbered in ascending order, it is recommended:

- To connect the WHISKER-QP-MIPI60-Q connected to the QUADPROBE socket A to the connector with the lowest number.
- To connect the WHISKER-QP-MIPI60-Q connected to the QUADPROBE socket B to the connector with the next higher number and so on.

5. Start the TRACE32 software.

6. Power your target.

Information on how to set up your debug environment can be found in the following manuals:

- [“Intel® Application Note for Server Setup”](#) (app_x86_server.pdf)
- [“Intel® x86/x64 Debugger”](#) (debugger_x86.pdf).

Extra (CONV-MIPI60Q-XDP60)

If your target provides one or more Intel® XDP60 connectors, you have to use the converter CONV-MIPI60Q-XDP60. It converts the “Intel® MIPI60 Converged” pinout from the WHISKER-QP-MIPI60-Q to Intel® XDP60 pinout.

Connect CONV-MIPI60Q-XDP60 to each flex extension cable for each WHISKER-QP-MIPI60-Q.

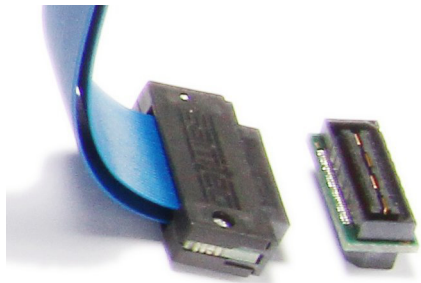

Then continue as described on the previous page.

Extras (POWER Connector)

POWER DEBUG INTERFACE / USB 3 is able to drive a QUADPROBE with 4 WHISKER-QP-MIPI60-Q cables.

Older POWER DEBUG modules do not have enough power. For these modules the QUADPROBE is equipped with an additional POWER connector.

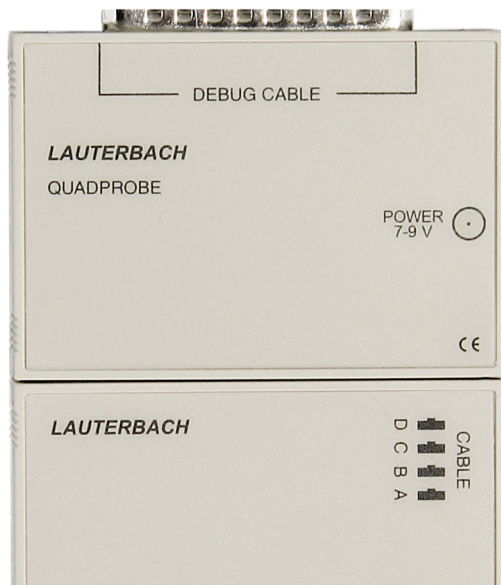

Both power supplies offered by Lauterbach are suitable:

- LA-1952 POWERSUPPLY-PP
- LA-1955 POWERSUPPLY-SPU65

Extra (USB-2-CABLE)

For more information refer to [“Extra \(USB-2-CABLE\)”](#), page 19.

Extra (TRIGGER-CONNECTOR)

For more information refer to [“Extras \(TRIGGER-CONNECTOR\)”](#), page 20.

Extra (USB-2-CABLE)

If your host computer does not provide a USB 3.0 interface or if the USB 3 communication is weak, you can use USB-2-CABLE as an alternative.

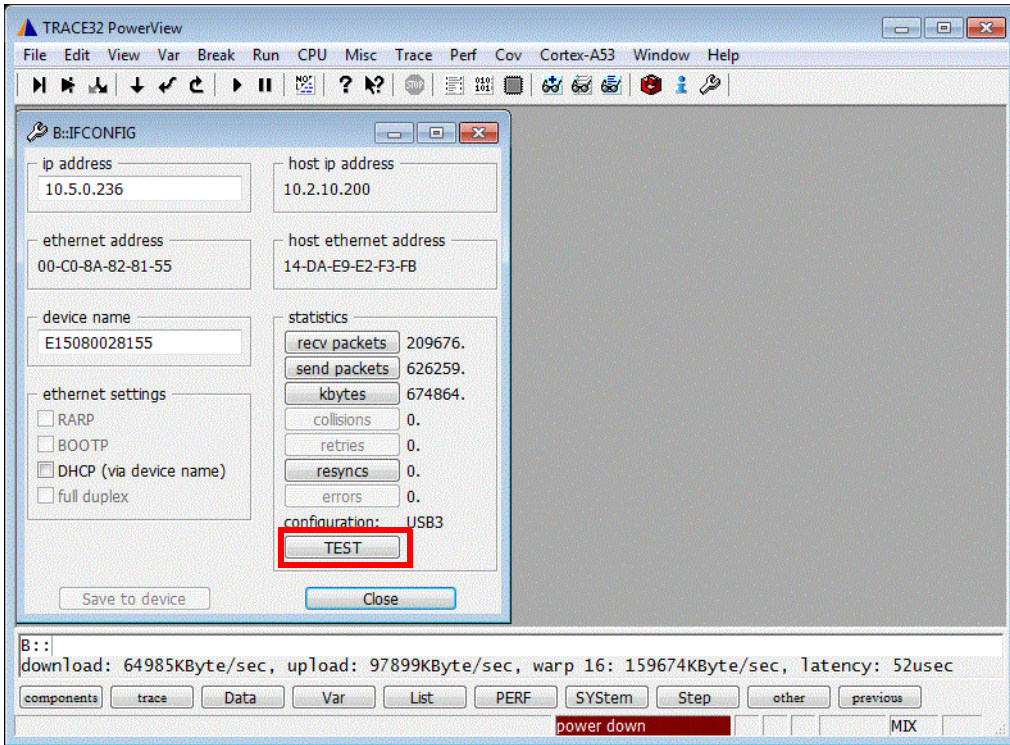

Use **Interface Config** from the **Misc** menu to open an **IFCONFIG** window. Use the **TEST** button to test the communication quality. Lauterbach considers the connection to be weak if the **warp 16** value is smaller than 100 MB.

Extras (TRIGGER-CONNECTOR)

All Lauterbach POWER DEBUG modules provides a TRIG input/output. If this TRIG input/output is connected to the target:

- a trigger generated by TRACE32 can be used to trigger an external device e.g. a logic analyzer.
- a trigger generated by the target can be used to trigger TRACE32.

To use the TRIGGER-CONNECTOR, proceed as follows:

1. Build a trigger cable.

Open the BLACK COVER of the TRIGGER CONNECTOR.

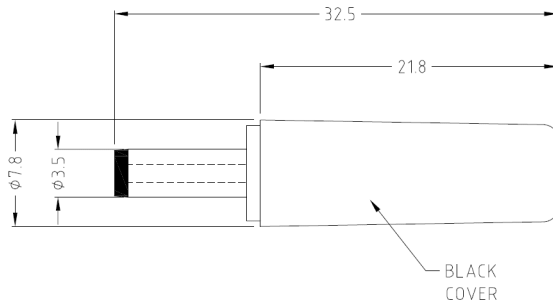

2. Solder the signal cable to SNG and the ground cable to GND.

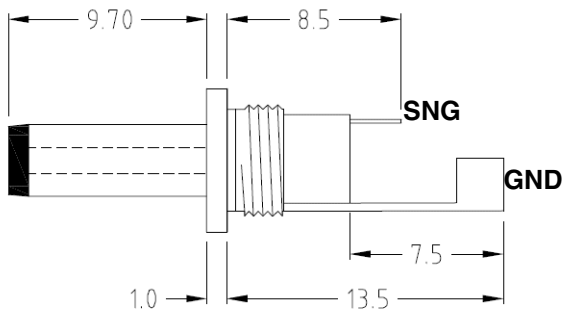

3. Connect the trigger jack to the TRIG connector of POWER DEBUG module.



4. Connect the signal cable and the ground cable to the external device/target.

The configuration of the trigger within TRACE32 is done via the **TRBUS** command group.